

AISIN at a Glance

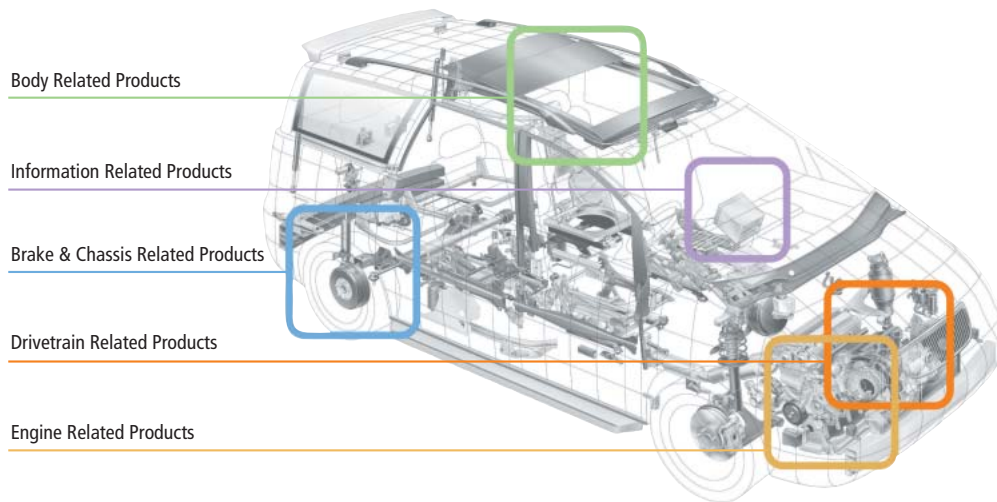

Drivetrain Related Products

- Automatic transmissions (ATs)
- Manual transmissions (MTs)
- Automated manual transmissions
- Continuously variable transmissions (CVTs)
- Hybrid systems
- Clutch discs
- Clutch covers

Net Sales and Percentage of Sales (Fiscal 2006)

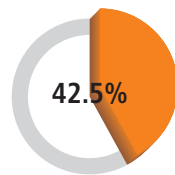

¥901,644 million (up 17.3%)

Net Sales for the Drivetrain Related Products Segment

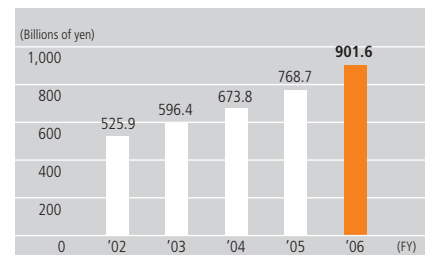

Brake & Chassis Related Products

- Drum brakes
- Disc brakes
- Brake booster and master cylinders
- Antilock brake systems (ABSs)
- Electronic stability controls (ESCs)
- Air suspension systems

Net Sales and Percentage of Sales (Fiscal 2006)

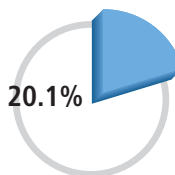

¥425,182 million (up 14.3%)

Net Sales for the Brake & Chassis Related Products Segment

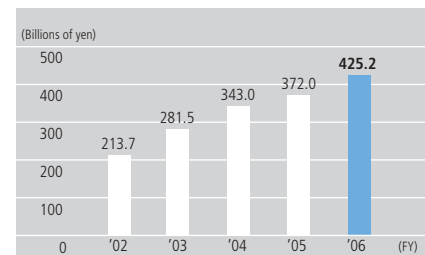

Body Related Products

- Door latches
- Power sliding door systems
- Power back door systems
- Sunroofs
- Power seats
- Occupant weight sensors
- Door frames

Net Sales and Percentage of Sales (Fiscal 2006)

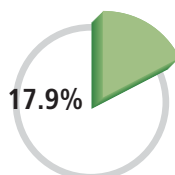

¥379,549 million (up 19.4%)

Net Sales for the Body Related Products Segment

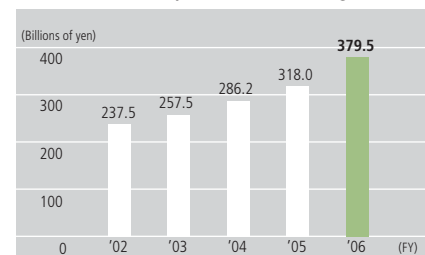



Engine Related Products

- Water pumps
- Oil pumps
- Pistons
- Intake manifolds
- Exhaust manifolds
- Variable valve timings (VVTs)

Net Sales and Percentage of Sales (Fiscal 2006)

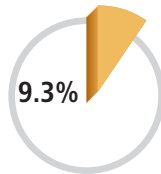

¥197,399 million (up 13.7%)

Net Sales for the Engine Related Products Segment

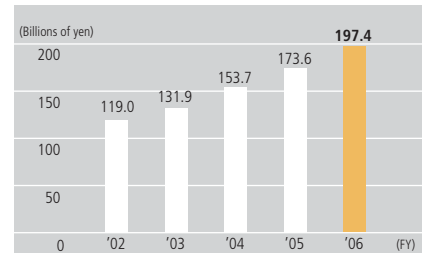

Information Related Products

- Car navigation systems
- Parking assist systems
- Lane departure warning systems
- Front and side monitors
- Intelligent Parking Assist

Net Sales and Percentage of Sales (Fiscal 2006)

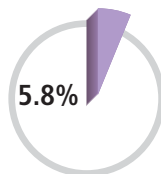

¥123,231 million (up 8.5%)

Net Sales for the Information Related Products Segment

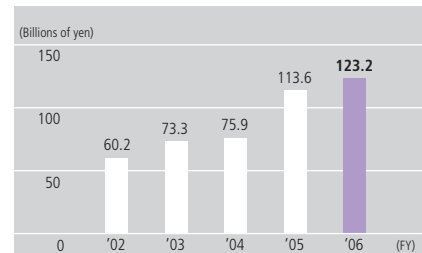

Casting Related Products

- Press components
- Aluminum die castings
- Iron castings
- Plastic moldings

No net sales recorded in fiscal 2006 as all transactions were incorporated into other product segments.

Life Related and Other Products

- Beds
- Sewing machines
- Shower-toilet seats
- Gas engine driven heat-pump air conditioners (GHPs)
- Gas engine cogeneration systems
- Residential remodeling
- Electronic wheelchairs
- Self-support reclining beds

Net Sales and Percentage of Sales (Fiscal 2006)

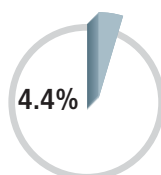

¥93,584 million (up 12.6%)

Net Sales for the Life Related and Other Products Segment

